

The Millstone enhances the traditional design with three spiralling forms in the ratio of the 'Golden Mean' or 'Divine Proportion' found widely in Nature.

The water rising in the centre of the form develops a side to side oscillation like a natural spring. This sends out a pattern of gentle waves across the surface and creates a series of relaxing and rhythmical sounds.

The Millstone is suitable for a wide range of garden, indoor and outdoor settings.

Design © Flowform Design Ltd



MILLSTONE

Ebb & Flow Ltd

Ruskin Mill Old Bristol Road Nailsworth

Gloucestershire GL6 0LA

Tel/Fax: 01453 836060

Email: info@ebbandflowltd.co.uk

www.ebbandflowltd.co.uk

Millstone Technical

Flow rate: 20 litres/min
Diameter: 570 mm (Millstone only)
Height: 120 mm (Millstone only)

In the droplet pebble pool tank:

Width: 820 mm
Length: 1010 mm
Height: 495 mm
Weight: 47 kg
Material: Cast granite stone with hand etched finish
Colour: Red or green

Plan view

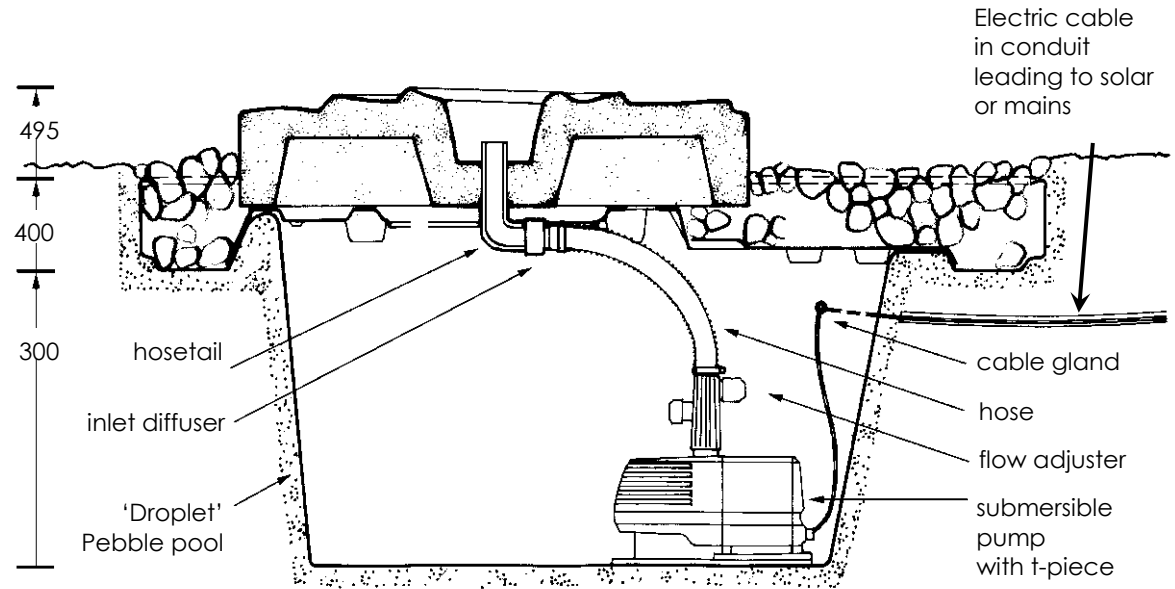
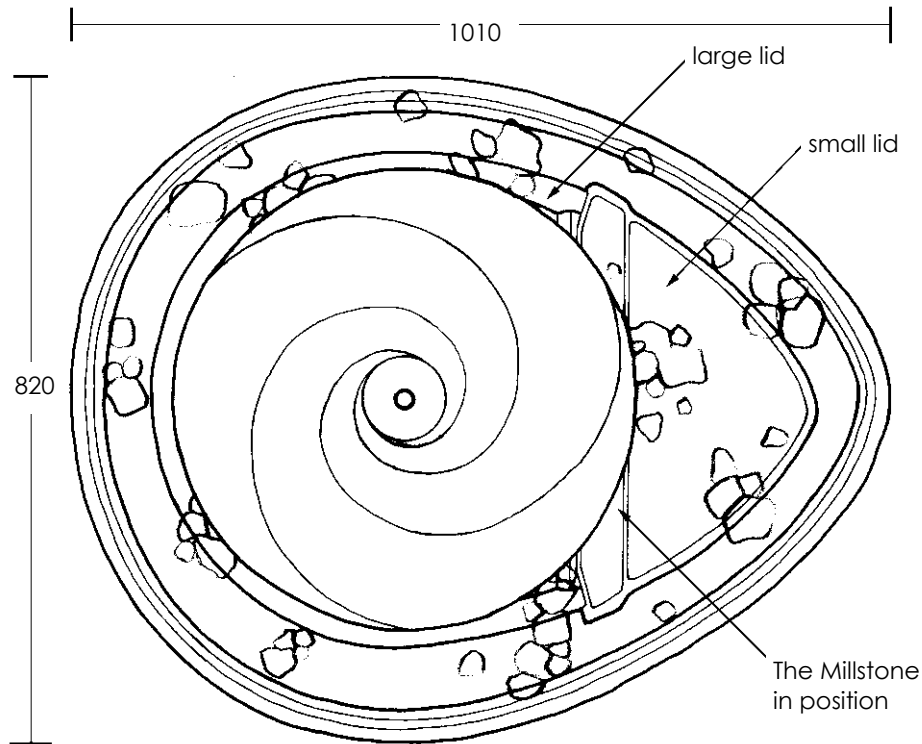

All dimensions in mm

Droplet Pebble pool installation guide

The Millstone shown above is complete with the Droplet pebble pool plus:

- 2 lid sections
- supply pipe-work fittings and hose
- 230 V submersible pump and fittings with 10m of cable
- instructions and guarantee.
- Pebbles not included - approximately 60kg are required

Installation and Maintenance Instructions

Installation

The features can be sited in a paved area, in a border, a lawn or gravel bed. They can also be set in a raised bed enclosed with a low wall or a timber surround to give stronger engagement. These instructions are for the ground level installation but it should not be difficult to see how to adapt them for the raised bed.

- Set aside the cast stone sculpture with its attached supply pipework, fittings and hose and the pump. Remove the two lids from the droplet pool.
- To install the droplet pool, first mark out its shape on the ground. Dig a hole equal to the depth of the tank and of the same shape allowing for the ledges. Conceal the rim of the reservoir below the finished ground level as appropriate for the chosen surround e.g. paving, peddles or lawn. If you have a stony or uneven ground, make the hole 25mm deeper and 50mm wider and longer than the pool. Cover the hole with a 25mm layer of the sand for support and allow for final adjustment of the pool to level.
- Provide a suitable electrical supply paying close attention to the electrical and safety advice supplied by the pump manufacturer. If in doubt consult a qualified electrician. The pump cable should be protected by a conduit as far as the junction box or mains socket.
- When you are ready to install the pool, place the pump and fittings into the base of the pool and thread the electric cable through the cable gland. Leave at least 1m of cable within the tank so that the pump may be lifted from the pool for maintenance. **It is important to securely tighten the cable gland nut on the inside of the tank with a 19mm spanner to create a watertight seal.**
- Place the reservoir in position. Check that the rim of the pool is level using a spirit level along the width and length. Backfill around the sides with soil or sand, making sure that it is well consolidated particularly under the ledges. If you intend to pave around the feature or expect heavier foot traffic, the backfill should be an aggregate or concrete. The pool should be slowly filled with clean water as the backfill is being placed around it (it will hold approximately 120 liters/26 gallons when full).
- Place the larger of the two lids in position on top of the reservoir. Insert the inlet pipe into the opening in the base of the flow-form and push it home. The joint may be permanently fixed with clear silicone if necessary. Place the feature on top of the lid, in the position shown on the drawing overleaf. By reaching underneath the lid into the open tank, hand tighten the hose tail onto the thread of the inlet pipe. Fix the free end of the hose onto the outlet of the T-piece and secure by screwing tight the jubilee clip. If the pool has not been filled, top it up with water to cover the pump as required.
- Switch on the pump. Check that the feature is operating smoothly and evenly. Adjust its level if not.
- Place the smaller lid in position. Finish with peddles or stones around the feature, leaving space for plants or open water as desired. Since the water from the feature returns to the reservoir via the ledges, only the water permeable material such as small pebbles or gravel should be used. Some plants are best in their pots some can root in loose stone.

Maintenance

Under normal circumstances your water sculpture should require little maintenance other than brushing off algal growth.

- The feature may be operated with the maximum water level to the rim of the pool. At a minimum the water container should be at least half full of water with the pump fully submerged. Air bubbles at the top of the form or the sound of the water returning to the pool becoming noticeably louder are the signs that the pump may not be covered and a top up is required. Add clean water within the rim of the pool as needed.
- Cleaning:-Depending on the location of the feature, it may be necessary to clear leaves or other debris from it. Cleaning algae from the surface of the feature is best done with a stiff nylon brush. This will be less if a timer is installed to give drying time at night. If excessive algal growth is allowed to build up, this may disrupt the effect of the water movement. If there is an accumulation of dust or dirt in the water, it may be necessary to change it. Gain access to the pump by removing the small triangular cover, unscrew the hose tail from the inlet pipe and place in a bucket or container. By running the pump, water can be decanted from the pool. Any remaining water and sediment can then be sponged from the bottom of the container. Refill with clean water.
- Maintenance of the pump should be carried out as specified in the pump manufacturer's instructions. If access to the pump is required without removing the feature, switch off the electrical supply, remove the pebbles and lift off the smaller lid to gain access to the water reservoir and pump.
- It is quite normal for the sculpture to acquire a natural patina over the period of time, as a result of natural weathering processes. Generally, this enhances the appearance of the feature.